

B.E. Sem. IV (Mech/Auto)

June - 2009

Industrial Drafting and Machine Design

11 JUN 2009

Time : 4 Hours]

[Max. Marks : 100

- Instructions :
- (1) Attempt all questions.
  - (2) Figures to the right indicate full marks.
  - (3) Assume suitable data wherever necessary.

1. Attempt any **four** from the following : 16
- (a) Difference among the shaft, axle and spindle.
  - (b) State the different design considerations to be considered while designing machine components.
  - (c) What are the reasons for using factor of safety ? Why its values are different for different applications ?
  - (d) How compressive stress, crushing stress and bearing stress differs ? Explain with neat sketches.
  - (e) State the functions of the springs and give two applications of each function.
  - (f) Distinguish between knuckle joint and cotter joint.
2. (a) A bell-crank lever is subjected to a load of 10 kN at short arm end. The arm lengths are 15 cm and 45 cm. The cross-section of the lever is rectangular with the depth to width ratio of lever (b/h) as 2.5. The ratio of length to diameter for pin is 1.3. The design stresses for pin and lever materials are  $85 \text{ N/mm}^2$  and  $50 \text{ N/mm}^2$  in tension and shear respectively. The permissible bearing pressure is  $12 \text{ N/mm}^2$ . Design the lever and fulcrum pin. 08

OR

- What are the factors to be considered for selection couplings ? Differentiate between the rigid couplings and flexible couplings.
- (b) Prove that the bending stresses in full-length leaves are 50% more than those in graduated-length leaves. 10
3. Attempt any **two** : 16
- (a) Design a knuckle joint used to connect two rods subjected to a maximum load of 19 kN. The rod is having circular cross section. The permissible stresses for rod and pin materials are  $78 \text{ N/mm}^2$ ,  $56 \text{ N/mm}^2$  and  $120 \text{ N/mm}^2$  in tension, shear and crushing respectively.
  - (b) The following data is given for a rigid coupling :

Outer diameter of the flanges	=	160 mm
Diameter of recess	=	95 mm
Number of bolts	=	6
Pre-load of each bolt	=	10 kN
Coefficient of friction	=	0.15
Speed of rotation	=	100 rpm

The bolts are set in large clearance holes. Calculate the power transmitting capacity of the coupling.

- (c) A transmission shaft, supporting two pulleys P and Q and mounted between two bearings  $B_1$  and  $B_2$  as shown in figure 3.1. Power is transmitted from Pulley P to Q. The shaft is made of plain carbon steel 45C8 having ultimate tensile strength and yield point strength are  $600 \text{ N/mm}^2$  and  $380 \text{ N/mm}^2$  respectively. The pulleys are keyed to the shaft. Determine the shaft diameter using the ASME code if,  $K_b = 1.5$  and  $K_t = 1.0$

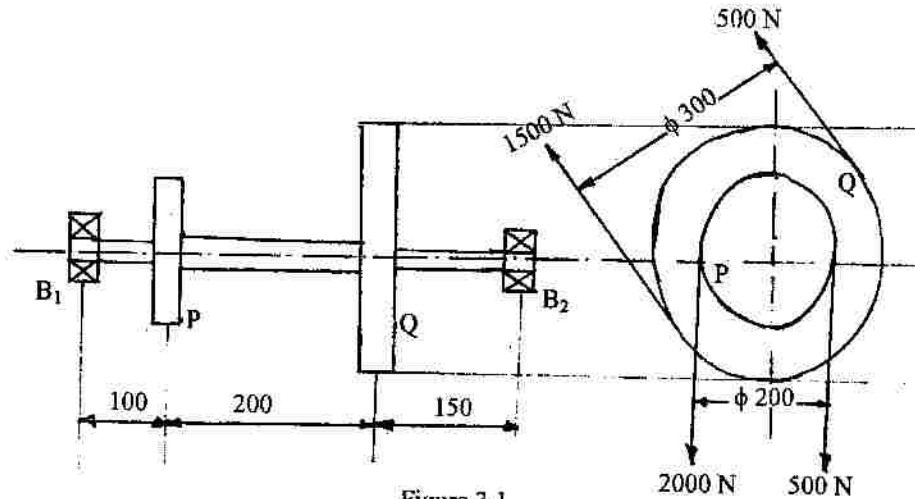

Figure 3.1

4. (a) An eccentric cam, 10 cm in diameter, rotates with an eccentricity of 10 mm as shown in figure 4.1. The roller follower is held against the cam by means by a helical-compression spring, the force between the cam and the follower varies from 100 N at the lowest position to 350 N at the highest position of the follower. Design the spring from static consideration and determine the factor of safety for fatigue considerations. Neglect the effect of inertia forces.

10

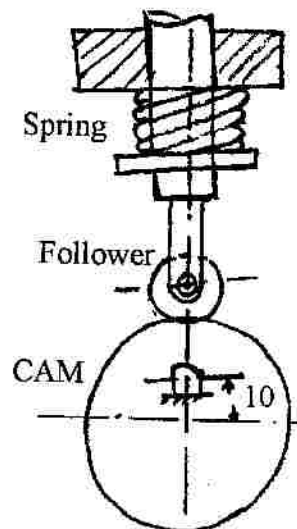

Figure 4.1

Mechanical Properties of oil-hardened and tempered spring steel wire (SW Grade)

Wire Diameter d (mm)	2.0	2.5	3.0	4.0	4.5	5.0
Min. tensile strength (N/mm <sup>2</sup> )	1620	1570	1520	1480	1440	1440

Also,  $K_s = 1.083$  and  $K = 1.253$ , for oil-hardened and tempered steel wire.

OR

A semi-elliptic leaf spring consists of two extra full-length leaves and eight graduated-length leaves, including the master leaf. The center-to-center distance between the two eyes of the spring is 1 m. The maximum force acting on the spring is 12 kN and the width of each leaf is 50 mm. The spring is initially pre-loaded in such a way that when the load is maximum, the stresses induced in all the leaves are equal to 350 N/mm<sup>2</sup>. Determine (i) the thickness of leaves and (ii) the deflection of the spring at maximum load.

(b) Explain with neat sketch different forms of threads. 06

5. (a) It is required to design a double-start screw with square threads for the C-clamp shown in figure 5.1. The maximum force exerted by the clamp is 5 kN. It is assumed that the operator will exert a force of 275 N at the ball handle of the hand wheel. The screw is made of plain carbon steel having yield point stress 335 N/mm<sup>2</sup>, while the nut is made of grey cast iron FG200. The dimensions of the collar are given in the figure 5.2. The factor of safety is 2.5. Determine the dimensions of the screw and the nut and calculate the radius  $R_m$  of the ball handle. 10

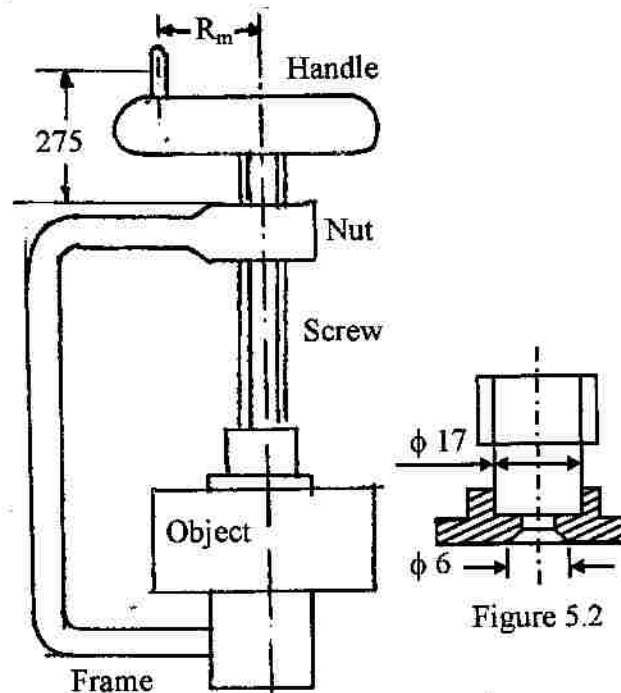

Figure 5.1

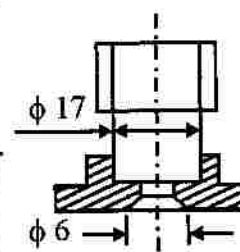

Figure 5.2

OR

A sluice valve used in water pipelines, consist of a gate raised by the spindle, which is rotated by the hand wheel. The spindle has single start square threads. The nominal diameter is 36 mm, and the pitch is 6 mm. The inner and outer diameters of the friction collar are 30 mm and the 50 mm respectively. The coefficient of friction at the threads and the collar are 0.15 and 0.20 respectively. The weight of the gate is 7.5 kN, and the frictional resistance to open the valve due to water power is 2.5 kN. Using the uniform wear theory for collar friction, calculate :

- (i) the torque required to raise the gate and
  - (ii) the overall efficiency of the mechanism.
- (b) List the different types of failures of riveted joint. Explain any two of them. **06**
6. Write a short note on any **three** from the followings : **18**
- (a) Nipping of the leaf springs
  - (b) Recirculating ball screw
  - (c) Strength based design using suitable examples.
  - (d) Different applications of lever with suitable example of each type.
  - (e) Walh's factor